

Standard Full Nut

Thread Type: Metric - Coarse

Thread Direction: Right Hand

Material: Solid Brass

Class Grade: Low Tensile Class 4.6

Corrosion Protection Level: Ultimate

Standard: AS 1112

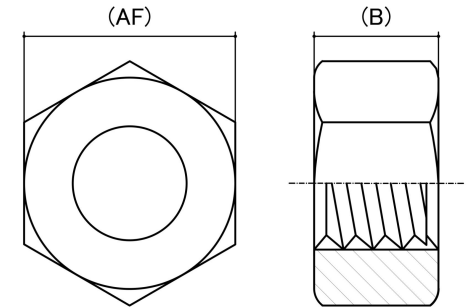

*Cad Drawings shown for graphic representation only.**

Size	Thread Pitch (mm)	Thread Type	Overall Nut Height (B) (mm)		Across Flats (AF) (mm)		Spanner Size (AF) (mm)	sku (Part Number)
			Min	Max	Min	Max		
M2.5	0.45mm	Coarse	1.75	2.00	4.82	5.00	5mm	41B25
M3	0.50mm	Coarse	2.15	2.40	5.32	5.50	5.5mm	41B3
M4	0.70mm	Coarse	2.90	3.30	6.78	7.00	7mm	41B4
M5	0.80mm	Coarse	4.40	4.70	7.78	8.00	8mm	41B5
M6	1.00mm	Coarse	4.90	5.20	9.78	10.00	10mm	41B6
M8	1.25mm	Coarse	6.44	6.93	12.73	13.00	13mm	41B8
M10	1.50mm	Coarse	8.04	8.40	15.73	16.00	16mm	41B10
M12	1.75mm	Coarse	10.37	10.80	17.73	18.00	18mm	41BM12
M16	2.00mm	Coarse	14.10	14.80	23.67	24.00	24mm	41B16

Disclaimer:

Dimensional data and technical information was obtained from publicly available sources and not acquired through standard agencies. It has been completed and compiled for reference purposes only; where discrepancies are found they are subject to change without notice. Bolt & Nut Australia makes no warranties or representations regarding the accuracy and validity of the compiled information and data. Contact the relevant standard authorities for accurate and detailed information.

* Cad Drawings may not reflect diameter, thread length or overall length.

© Bolt & Nut Australia Pty Ltd. All rights reserved.

Version: 25 Aug 2024